

# AIRTECH

## 可攜式無塵工作桌 CLEAN BENCH

Small · light · dust-free work desk

APC-43

### 1 Adopt energy saving and efficient DC brushless motor

The high-efficiency DC brushless motor can reduce power consumption and greatly save power consumption (56% lower than the previous generation).

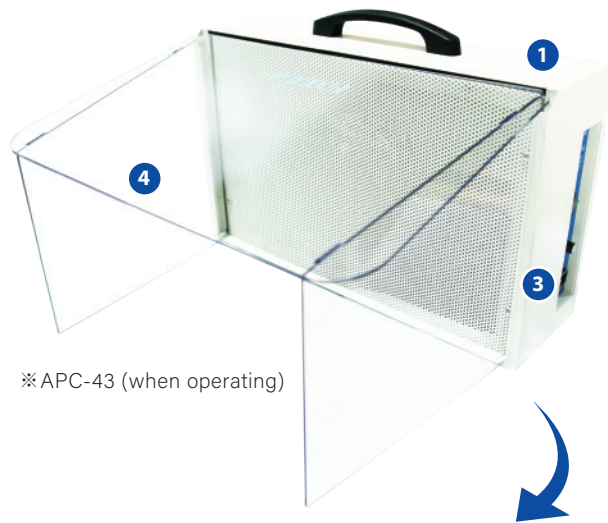

### 3 Built-in transformer

AC 110~240V 1Φ 50/60Hz full voltage input, easy to use.

### 2 Lightweight

It is lighter than the previous model and easy to carry (40% less than the previous model).



### 4 Easy to assemble and store

The used air deflector can be stored in the front of the device, which is easy to carry and does not take space.



#### Control panel

Operation switch, fuse cartridge, power hole, simple and intuitive operation configuration.



#### Non-slip handle design

Long handle, no-slip design, and more stable in use.



#### HEPA filter

Primary nylon filter with HEPA high-efficiency filter to effectively filter the suspended particles.

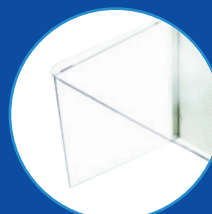

#### Transparent PC partition

Quickly self-assemble, storage and high light transmittance, good practicability.

## Drawing

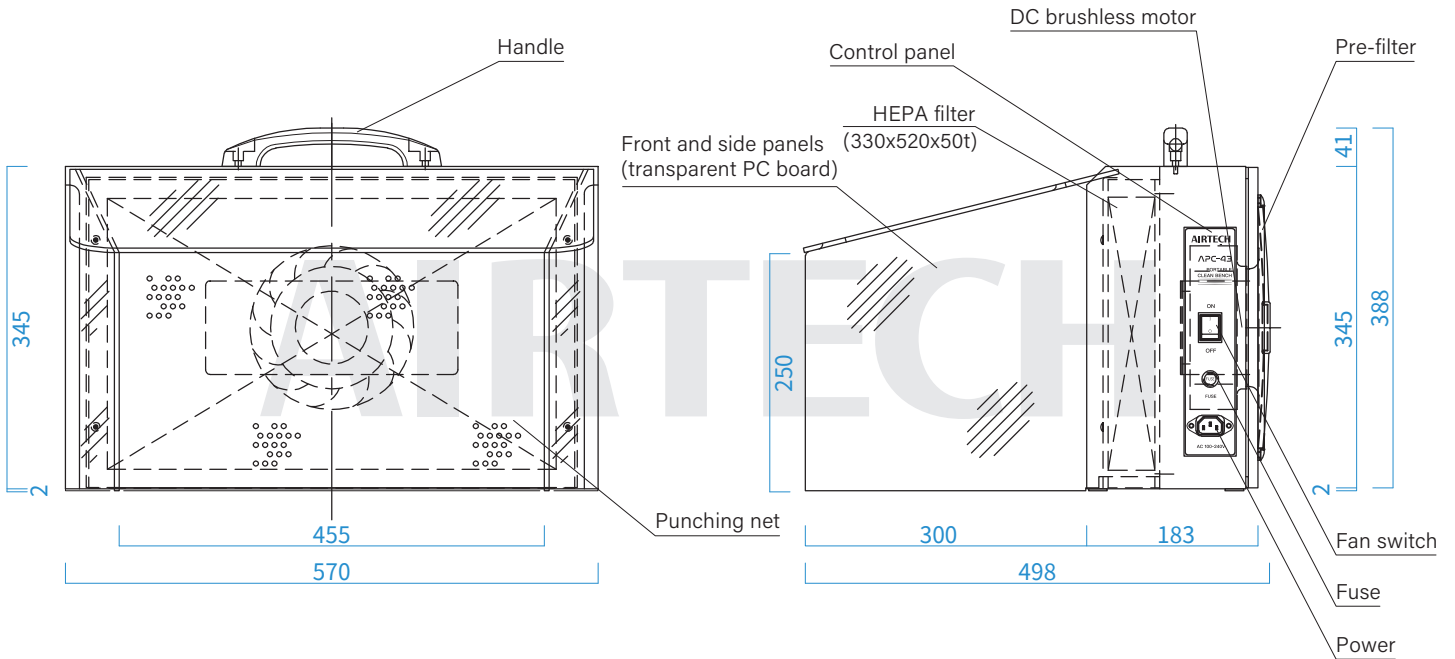

## Specification

Model	APC-43
Cleanliness	ISO Class 5 (Class 100 <US. FED. STD. 209D>)
Particle Efficiency	Above 99.99% Efficient On 0.3 $\mu$ m Particles
Dust Collection	Pre-filter : Nylon filter $\varnothing$ 284 x1EA Main filter : HEPA filter 330x520x50t 1pc
Air Volume(CMM)	About 3.3
Air Velocity(m/s)	About 0.35
Structure	Cold-rolled steel with bake painting
Electrical	AC 110~240V 1 $\Phi$ 50/60Hz
Blower	DC Blower x 1 SET (made in Japan)
Power Consumption(W)	About 22
Weight(kg)	About 12.5